

June 27, 1997
 EnviroSeal Engineering Products Ltd.

Distributor Memo

New Patent Explains Problems with Tapered Seal Chambers

A new US patent (#5630699) discloses problems with protruding flow modifiers as used in open bore and tapered seal chambers. As a result of seal erosion experienced in chambers equipped with axial flow modifiers, the new patent is granted for an arrangement that makes both the flow modifiers and the eroded seal parts **REPLACEABLE!** Problems disclosed in the patent will be interesting to all distributors.

As an introduction, the new patent describes the problem with a regular taper bore chamber:

"The abrasive fluid thus undergoes a flow reversal adjacent the gland which, coupled with rotational centrifugal effects on heavier particles which tend to collect in the outer corner of the chamber, effect erosion and hence wear of the gland ring at an undesirably rapid rate."

The flow and centrifuge trap abrasives at the gland area and erode the components.

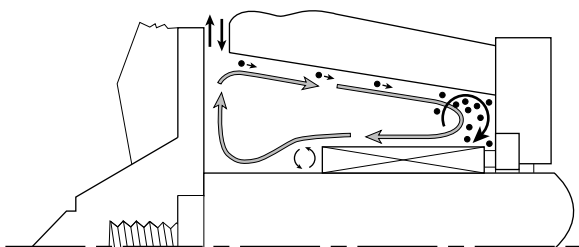

Fig. 1 EnviroSeal diagram showing collection of abrasives at the gland area due to the action of flow and centrifuge.

Regarding the "speed bump" arrangement, the patent explains:

"In an effort to minimize such erosion-induced wear, some pumps have recently been provided with axially-extending protrusions fixed to or adjacent the outer wall of the enlarged-bore seal chamber These protrusions have been observed to at least provide some improvement in the fluid circulation pattern, ...but it has been observed that most of the proposals and structures have so far failed to significantly minimize or eliminate erosion-induced wear of the gland ring."

This indicates that the protrusions are effective at stopping erosion on the bore, **but fail to prevent erosion on the gland.** If there is abrasive erosion to the gland, then there is surely a significant implication on the life

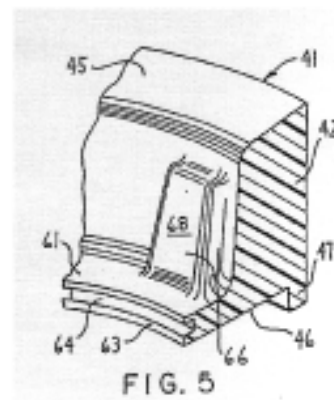

Fig. 2 Diagram from US Patent 5630699 showing an axially-extending protrusion (speed bump) on new invention.

of the other seal components as well. Obviously abrasives are not being expelled from the chamber, but are simply deflected away from the bore towards the gland and seal.

Describing the new invention, the patent states:

"The protector preferably occupies a significant part of the volume of the enlarged-bore chamber to minimize the quantity of pump fluid entering therein, and is effective in significantly eliminating direct erosion-contact to the pump fluid against both the gland ring and the surrounding wall of the seal chamber. The annular protector is preferably stationary but removably attached to the gland ring so as to permit it to be readily removed and **replaced when worn**, whereby shutdown and repair of the seal can be accomplished quickly and economically."

These statements clearly indicate that the action of the bore protrusions produces an erosion problem on

the mechanical seal. The patent proposes a special seal and backplate design with replaceable parts that the customer can rebuild. In this they are also saying that if normal seals are used in chambers with bore projections, the customer risks premature failure and repair costs. Also, by the description, it is indicated that the very large chamber designs are not warranted in the first place, and that when used they lead to premature seal damage.

The new seal and cavity design proposed in this patent do not attempt to solve the problem, but rather to provide a replaceable wear component to sell to the customer. This points out the advantage of doing the job right in the first place. ***If the abrasives are not allowed to stay in the chamber, they cannot cause erosion and the seals will last longer. No special or armored seal replacement parts are necessary!*** This is the design philosophy taken with all EnviroSeal products. The simple installation of SpiralTrac™ or QMax™ eliminates seal erosion.

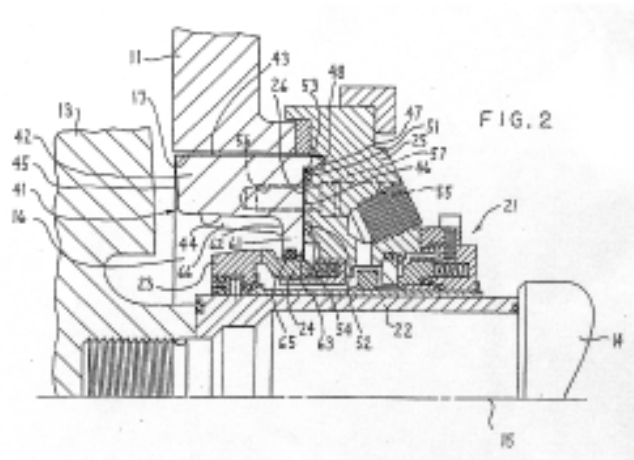

Fig. 3 Diagram from US Patent 5630699 showing the new invention installed in a pump. Note how the device reduces the chamber size.

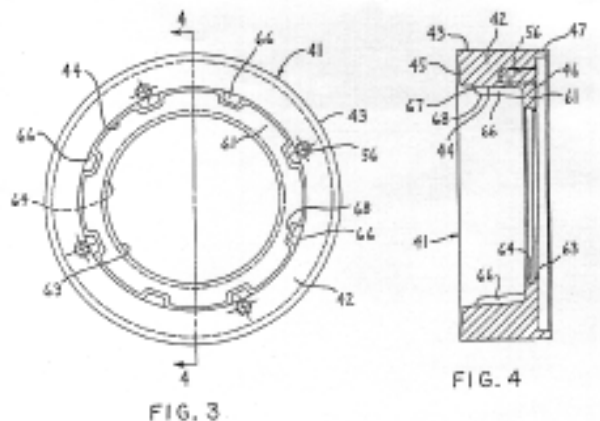

Fig. 4 Diagrams from US Patent 5630699 showing a front and section view of the new invention. The device has been designed on the premiss that it will wear due to erosion and therefore require replacement.