

33K SBP

Split Bearing Protection Seal

Product Data

The innovative 33K split design eliminates the need and associated costs for equipment disassembly while improving seal performance of conventional lip seals.

The 33K can be used in many applications including bearing protection for pumps, gearboxes and rollers. Installation time can be reduced from hours to minutes because the split assembly is unitized installing quickly and easily.

The seal is a combination of two different material types.

- The monolithic housing is made from a 95A durometer polyurethane that energizes and provides easy mounting to the equipment.
- The sealing interface is made from high performance filled PTFE material developed specifically for sealing applications.



Fast

- The patent pending split design eliminates the need and associated costs for equipment disassembly.

Easy

- No need for equipment modification since all seals are made to order.

Reliable

- High performance materials are field-proven to outperform conventional seals.



No Need To Disassemble Equipment

Material Selection & Typical Applications*

PTFE Compound	Dry	Water	Petroleum Based Liquids
AWC 100 - Polyimide Filled	Excellent	—	Excellent-Low Viscosity
AWC 300 - Moly & Glass Filled	Good	Good	Excellent-High Viscosity (>2,000 cp)
AWC 400 - Carbon & Graphite Filled	Good	Excellent	Good

* Performance depends on concurrent conditions including shaft hardness, shaft surface roughness, speed, materials lubrication, temperature and pressure.

Operating Temperature Range –°F (°C)

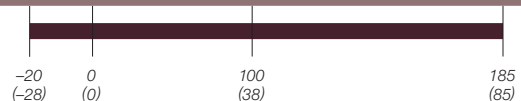

Recommended Surface Finishes – μ inch (μ m)



Recommended Mating Surface Hardness

AWC 100	AWC 300	AWC 400
>45 Rockwell C	>55 Rockwell C	>55 Rockwell C

33K SBP

Split Bearing Protection Seal

Cross Sectional Drawing of Equipment

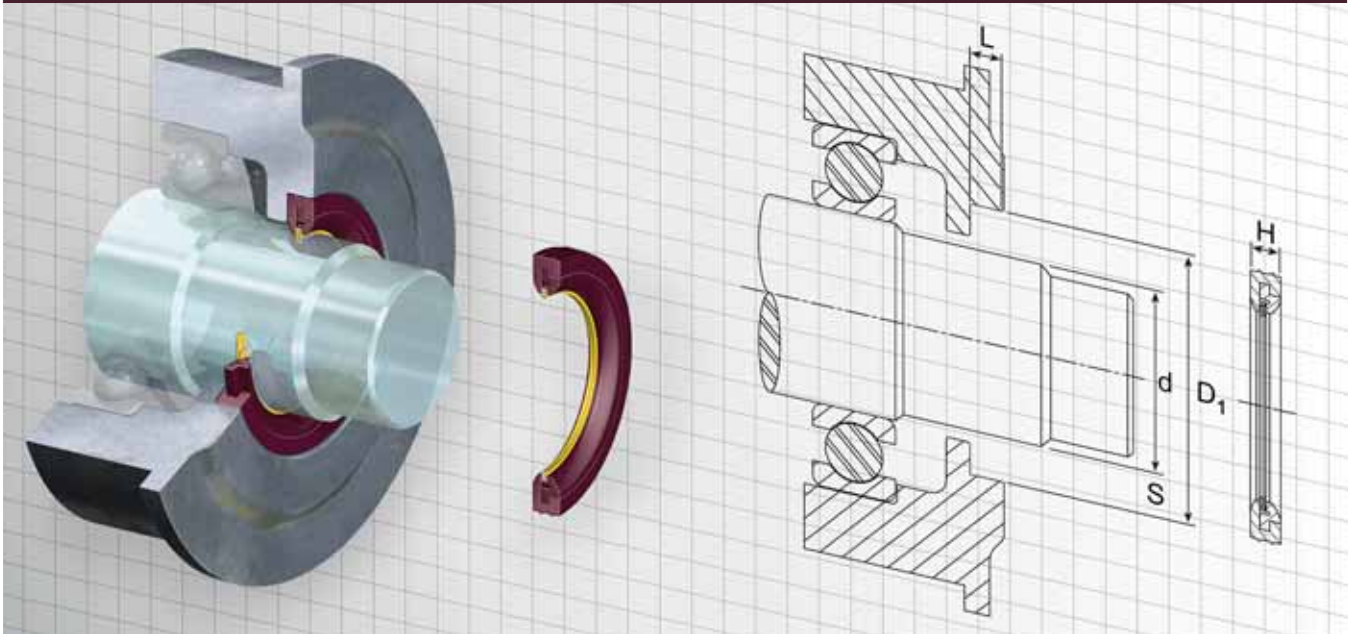

Technical Data

Designations:

Shaft diameter = d
 Equipment bore = D_1
 Seal height = H
 Groove height = L
 Cross section = S

Available Seal Sizes

Shaft Diameter Range Inch (mm)

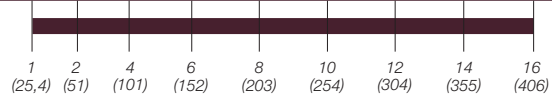

Shaft Diameter (d)	*Equipment Cross Section (S)	*Groove Height (L)
1 ≤ 16 inch (25,4 ≤ 406 mm)	0.270 ≤ 1.000 inch (6,8 ≤ 25,4 mm)	0.250 ≤ 1.125 inch (6,3 ≤ 28,5 mm)

* Maximum and minimum groove heights and equipment cross sections will vary by shaft diameter.

Operating Parameters

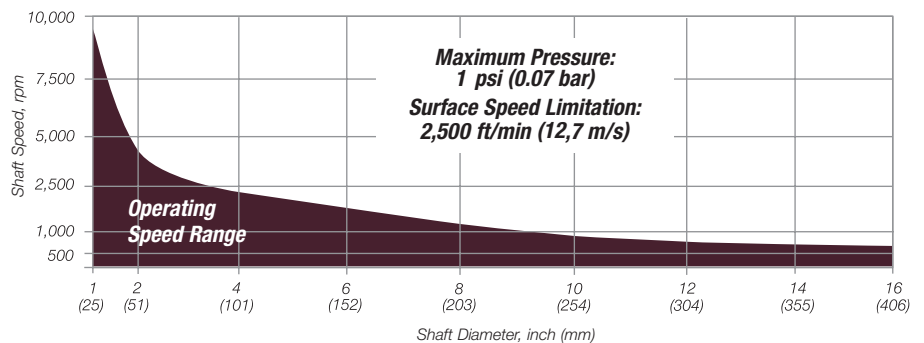

ISO certifications available at
www.chesterton.com/corporate/iso

Technical Data reflects results of laboratory tests and is intended to indicate general characteristics only.
 A.W. CHESTERTON CO. DISCLAIMS ALL WARRANTIES EXPRESSED, OR IMPLIED, INCLUDING WARRANTIES OF MERCHANTABILITY AND FITNESS FOR A PARTICULAR PURPOSE OR USE. LIABILITY, IF ANY, IS LIMITED TO PRODUCT REPLACEMENT ONLY.



A Supporting Member of FSA/ESA
 860 Salem Street
 Groveland, Massachusetts 01834 USA
 Telephone: 978-469-6421 Fax: 978-469-6731
www.chesterton.com

© A.W. Chesterton Company, 2006. All rights reserved.
 ® Registered trademark owned and licensed by
 A.W. Chesterton Company in USA and other countries.

DISTRIBUTED BY:

FORM NO. 088800

PRINTED IN USA 11/06